

TECHNICAL MANUAL

OPERATOR'S, ORGANIZATIONAL, DIRECT SUPPORT  
AND GENERAL SUPPORT MAINTENANCE MANUAL  
INCLUDING REPAIR PARTS LIST  
FOR

ADAPTER SET, ENGINE  
MODEL 501-0  
HANDY TOOL AND MFG. CO., INC.  
(NSN 4910-00-348-7600)

---

HEADQUARTERS, DEPARTMENT OF THE ARMY

APRIL 1981



TECHNICAL MANUAL

No. 9-4910-703-14&P

HEADQUARTERS  
DEPARTMENT OF THE ARMY  
Washington, DC, 17 April 1981

Operator's, Organizational, Direct Support  
And General Support Maintenance Manual  
Including Repair Parts List  
For

**ADAPTER SET, ENGINE  
MODEL 501-0  
(HANDY TOOL AND MFG., CO., INC.)  
(NSN 4910-00-348-7600)**

REPORTING ERRORS AND RECOMMENDING IMPROVEMENTS

You can help improve this manual. If you find any mistakes or if you know of a way to improve the procedures, please let us know. Mail your letter, DA Form 2028 (Recommended Changes to Publications and Blank Forms), or DA Form 2028-2, located in the back of this manual direct to: Commander, US Army Armament Materiel Readiness Command, ATTN: DRSAR-MAS, Rock Island, IL 61299. A reply will be furnished direct to you.

Note

This manual is published for the purpose of identifying an authorized commercial manual for the use of the personnel to whom this adapter is issued.

Manufactured by: Handy Tool & Mfg., Co., Inc.  
39-09 58th Street  
Woodside, NY 11377

Procured under Contract No. DAAA09-78-C-5243.

This technical manual is an authentication of the manufacturer's commercial literature and does not conform with the format and content specified in AR 310-3, Military Publications. This technical manual does, however, contain available information that is essential to the operation and maintenance of the equipment.

## INSTRUCTIONS FOR REQUISITIONING PARTS

## NOT IDENTIFIED BY NSN

When requisitioning parts not identified by National Stock Number, it is mandatory that the following information be furnished the supply officer,

- 1 - Manufacturer's Federal Supply Code Number - 91750
- 2 - Manufacturer's Part Number exactly as listed herein.
- 3 - Nomenclature exactly as listed herein, including dimensions, if necessary.
- 4 - Manufacturer's Model Number - Model 501-0
- 5 - Manufacturer's Serial Number (End Item)
- 6 - Any other information such as Type, Frame Number, and Electrical Characteristics, if applicable.
- 7 - If DD Form 1348 is used, fill in all blocks except 4, 5, 6, and Remarks field in accordance with AR 725-50.

Complete Form as Follows:

- (a) In blocks 4, 5, 6, list manufacturer's Federal Supply Code Number - 91750 followed by a colon and manufacturer's Part Number for the repair part.
- (b) Complete Remarks field as follows:
 

Noun:	(nomenclature of repair part)
For:	NSN: 4910-00-348-7600
Manufacturer:	Handy Tool & Mfg. Co., Inc.

Model: 501-0  
 Serial: (of end item)

Any other pertinent information such as Frame Number, Type, Dimensions, etc.

## INTRODUCTION

The adapter set, Model 501-0, is for use in making test connections to 24 volt waterproof electrical systems in use on wheeled vehicles.

It consists of the following five (5) adapters:

Generator adptr	FSN 4910-092-9026
Regulator adptr	FSN 4910-092-9025
High tension adptr	FSN 4910-356-7504
Ignition unit adptr	FSN 4910-356-7508
Distributor primary adptr	FSN 4910-356-7492

## CONNECTION PROCEDURE FOR CHARGING CIRCUIT

## GENERATOR ADAPTER:

1. Disconnect generator cable at generator and plug generator adapter into socket.
2. Reconnect generator cable to free end of generator adapter. (See Figure 1.)

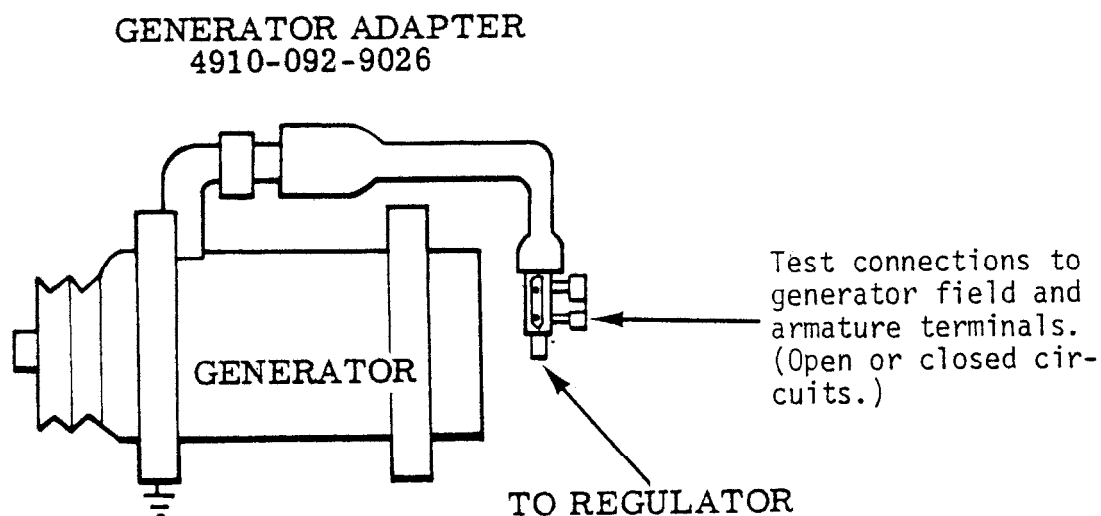

FIGURE 1.

## REGULATOR ADAPTER:

1. Disconnect regulator cable at regulator and plug adapter into regulator socket.
2. Reconnect regulator cable to free end of regulator adapter. (See Figure 2.)

**REGULATOR ADAPTER  
FSN 4910-092-9025**

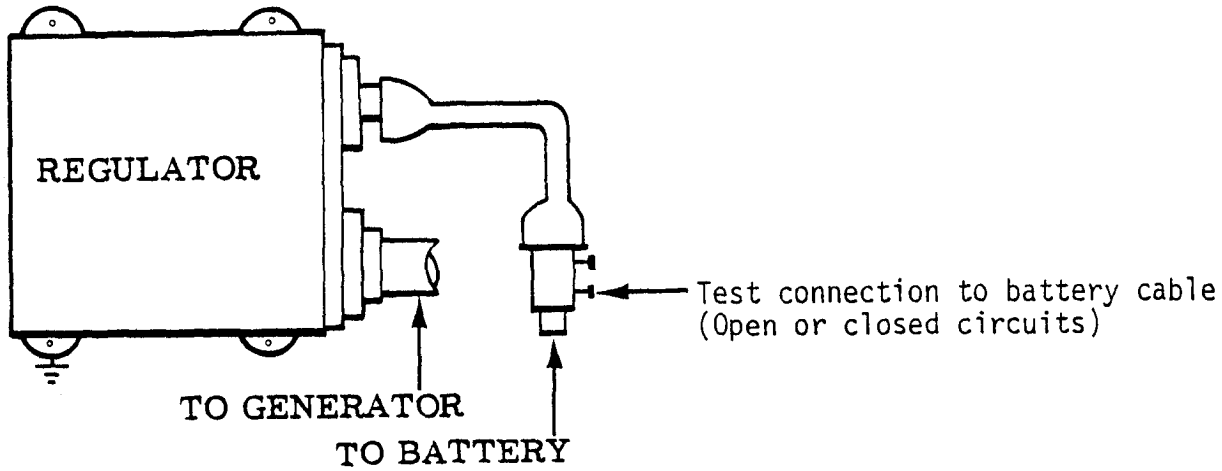

FIGURE 2.

Make tests required for charging circuit by connecting to generator and/or regulator adapters as indicated in instruction manual for specific test unit being used. After tests are made and adapters removed, make sure connections are secure and waterproof.

**IGNITION CIRCUIT TESTS**

**DISTRIBUTOR PRIMARY ADAPTER:**

1. Remove plug in distributor cover and screw distributor primary adapter securely into exposed hole. (See Figure 3.)
2. Refer to operating instruction manual of specific tester being used and connect accordingly.
3. Follow test sequence as outlined in vehicle service manual.

**DISTRIBUTOR PRIMARY ADAPTER**

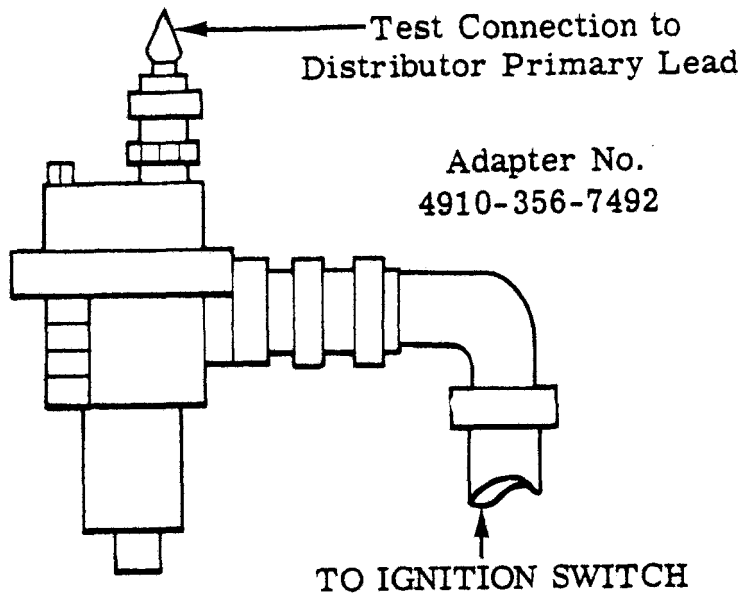

**IGNITION UNIT**

FIGURE 3.

**IGNITION UNIT ADAPTER:**

1. Remove cable to ignition unit and connect ignition unit adapter to exposed connector socket on ignition unit. (See Figure 4.)
2. Reconnect cable to open end of ignition unit adapter. Securely tighten all connectors.
3. Refer to operating instruction manual of test unit being used, and perform tests as indicated in vehicle service manual.
4. After tests have been completed and adapters removed, reconnect cables and make sure they are tight and waterproof.

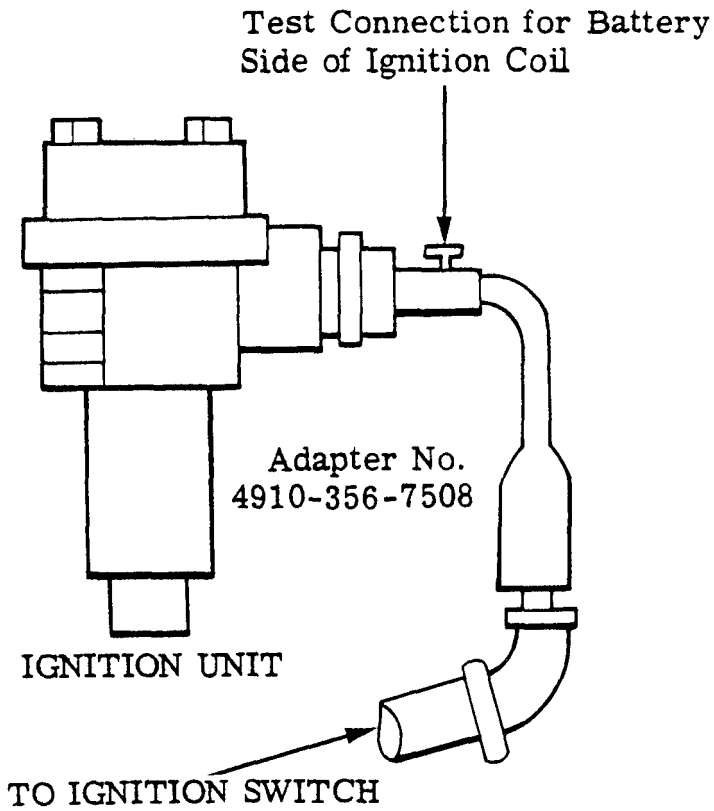

FIGURE 4.

HIGH TENSION ADAPTER:

1. Disconnect cable at any accessible spark plug and attach high tension adapter to spark plug.
2. Reconnect spark plug cable to high tension adapter and tighten securely. (See Figure 5.)

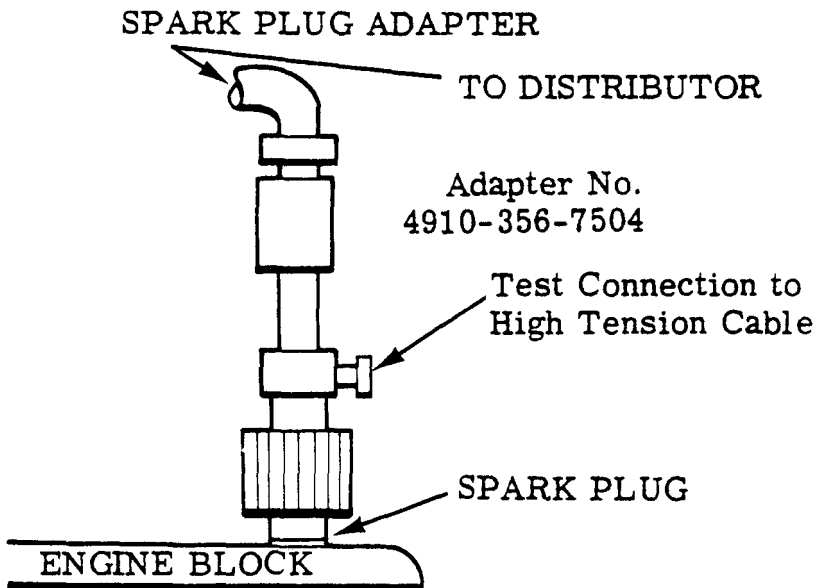

FIGURE 5.



3. Connect test leads of specific tester being used to high tension adapter test connection and ground. Proceed with tests in accordance with instructions as contained in vehicle service manual.

CARE OF ADAPTER SET

1. Observe caution when making connections that units are not cross threaded and damaged.
2. Keep units away from intense heat.
3. Wipe grease and dirt from external surfaces of adapters and clean threaded connections thoroughly.
4. Make sure all adapters are clean and dry when replaced in case.

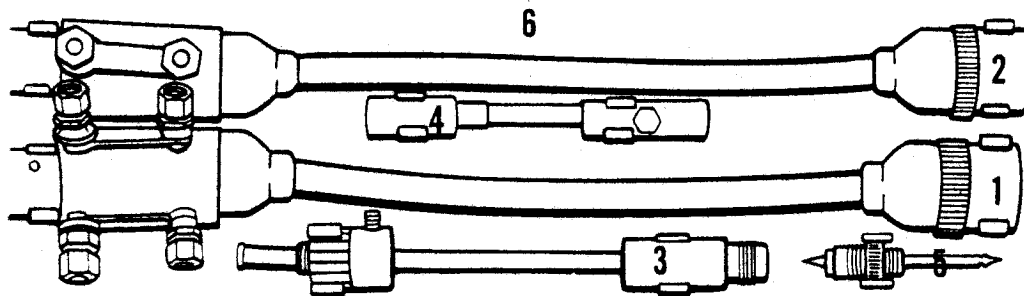

ADAPTER	F S N	ORD	P/N	PART	NO.
1. Generator	4910-092-9026	7541209		501-1	
2. Regulator	4910-092-9025	7541200		501-2	
3. Spark Plug	4910-356-7504	7540884		501-3	
4. Ignition	4910-356-7508	7540895		501-4	
5. Primary	4910-356-7492	7540877		501-5	
6. Box for Adptr	N O N E	7541362		501-6	

By Order of the Secretary of the Army:

Official:

J. C. PENNINGTON  
*Major General, United States Army*  
*The Adjutant General*

E. C. MEYER  
*General, United States Army*  
*Chief of Staff*

RECOMMENDED CHANGES TO EQUIPMENT TECHNICAL PUBLICATIONS



THEN... JOT DOWN THE DOPE ABOUT IT ON THIS FORM. CAREFULLY TEAR IT OUT. FOLD IT AND DROP IT IN THE MAIL!

**SOMETHING WRONG WITH THIS PUBLICATION?**

FROM: (PRINT YOUR UNIT'S COMPLETE ADDRESS)

Your mailing address

DATE SENT

Date you filled out this form

PUBLICATION NUMBER

TM 9-4910-703-14&P

PUBLICATION DATE

17 Apr 81

PUBLICATION TITLE Maintenance Manual  
for Engine Adapter Set -  
Model 501-0

BE EXACT... PIN-POINT WHERE IT IS

PAGE NO.	PARA-GRAPH	FIGURE NO.	TABLE NO.
12		3	

IN THIS SPACE TELL WHAT IS WRONG AND WHAT SHOULD BE DONE ABOUT IT:

Shows adapter No. 8830B; parts list gives no. 8832B for that adapter.

SAMPLE

PRINTED NAME, GRADE OR TITLE, AND TELEPHONE NUMBER

JOHN SMITH SP/3 XXX-XXXX

SIGN HERE:

*John Smith*

DA FORM 2028-2  
1 JUL 79

PREVIOUS EDITIONS ARE OBSOLETE.

P.S.—IF YOUR OUTFIT WANTS TO KNOW ABOUT YOUR RECOMMENDATION MAKE A CARBON COPY OF THIS AND GIVE IT TO YOUR HEADQUARTERS.

TEAR ALONG PERFORATED LINE

FILL IN YOUR  
UNIT'S ADDRESS

FOLD BACK

DEPARTMENT OF THE ARMY

OFFICIAL BUSINESS  
PENALTY FOR PRIVATE USE \$300

POSTAGE AND FEES PAID  
DEPARTMENT OF THE ARMY  
DOD 314



TEAR ALONG PERFORATED LINE

Commander  
US Army Armament Materiel Readiness Command  
ATTN: DRSAR-MAS  
Rock Island, IL 61299

RECOMMENDED CHANGES TO EQUIPMENT TECHNICAL PUBLICATIONS



THEN... JOT DOWN THE DOPE ABOUT IT ON THIS FORM. CAREFULLY TEAR IT OUT. FOLD IT AND DROP IT IN THE MAIL!

**SOMETHING WRONG** WITH THIS PUBLICATION?

FROM: (PRINT YOUR UNIT'S COMPLETE ADDRESS)

DATE SENT

PUBLICATION NUMBER

TM 9-4910-703-14&P

PUBLICATION DATE

17 Apr 81

PUBLICATION TITLE

ADAPTER SET, ENGINE MODEL 501-0

BE EXACT... PIN-POINT WHERE IT IS

PAGE NO.

PARA-GRAPH

FIGURE NO.

TABLE NO.

IN THIS SPACE TELL WHAT IS WRONG AND WHAT SHOULD BE DONE ABOUT IT:

TEAR ALONG PERFORATED LINE

PRINTED NAME, GRADE OR TITLE, AND TELEPHONE NUMBER

SIGN HERE:

DA FORM 2028-2  
1 JUL 79

PREVIOUS EDITIONS ARE OBSOLETE.

P.S.—IF YOUR OUTFIT WANTS TO KNOW ABOUT YOUR RECOMMENDATION MAKE A CARBON COPY OF THIS AND GIVE IT TO YOUR HEADQUARTERS.

FILL IN YOUR  
UNIT'S ADDRESS

FOLD BACK

DEPARTMENT OF THE ARMY

---

---

OFFICIAL BUSINESS  
PENALTY FOR PRIVATE USE \$300

POSTAGE AND FEES PAID  
DEPARTMENT OF THE ARMY  
DOD 314



TEAR ALONG PERFORATED LINE

Commander  
US Army Armament Materiel Readiness Command  
ATTN: DRSAR-MAS  
Rock Island, IL 61299

RECOMMENDED CHANGES TO EQUIPMENT TECHNICAL PUBLICATIONS



THEN... JOT DOWN THE DOPE ABOUT IT ON THIS FORM. CAREFULLY TEAR IT OUT. FOLD IT AND DROP IT IN THE MAIL!

**SOMETHING WRONG WITH THIS PUBLICATION?**

FROM: (PRINT YOUR UNIT'S COMPLETE ADDRESS)

DATE SENT

PUBLICATION NUMBER

TM 9-4910-703-14&P

PUBLICATION DATE

17 Apr 81

PUBLICATION TITLE

ADAPTER SET, ENGINE

MODEL 501-0

BE EXACT... PIN-POINT WHERE IT IS

PAGE NO.

PARA-GRAPH

FIGURE NO.

TABLE NO.

IN THIS SPACE TELL WHAT IS WRONG AND WHAT SHOULD BE DONE ABOUT IT:

TEAR ALONG PERFORATED LINE

PRINTED NAME, GRADE OR TITLE, AND TELEPHONE NUMBER

SIGN HERE:

DA FORM 2028-2  
1 JUL 79

PREVIOUS EDITIONS ARE OBSOLETE.

P.S.—IF YOUR OUTFIT WANTS TO KNOW ABOUT YOUR RECOMMENDATION MAKE A CARBON COPY OF THIS AND GIVE IT TO YOUR HEADQUARTERS.

FILL IN YOUR  
UNIT'S ADDRESS

FOLD BACK

DEPARTMENT OF THE ARMY

\_\_\_\_\_  
\_\_\_\_\_

OFFICIAL BUSINESS  
PENALTY FOR PRIVATE USE \$300

POSTAGE AND FEES PAID  
DEPARTMENT OF THE ARMY  
DOD 314



TEAR ALONG PERFORATED LINE

Commander  
US Army Armament Materiel Readiness Command  
ATTN: DRSAR-MAS  
Rock Island, IL 61299



RECOMMENDED CHANGES TO EQUIPMENT TECHNICAL PUBLICATIONS



THEN... JOT DOWN THE DOPE ABOUT IT ON THIS FORM. CAREFULLY TEAR IT OUT. FOLD IT AND DROP IT IN THE MAIL.

**SOMETHING WRONG WITH THIS PUBLICATION?**

FROM: (PRINT YOUR UNIT'S COMPLETE ADDRESS)

DATE SENT

PUBLICATION NUMBER

TM 9-4910-703-14&P

PUBLICATION DATE

17 Apr 81

PUBLICATION TITLE

ADAPTER SET, ENGINE

MODEL 501-0

BE EXACT... PIN-POINT WHERE IT IS

PAGE NO.

PARA-GRAPH

FIGURE NO.

TABLE NO.

IN THIS SPACE TELL WHAT IS WRONG AND WHAT SHOULD BE DONE ABOUT IT:

TEAR ALONG PERFORATED LINE

PRINTED NAME, GRADE OR TITLE, AND TELEPHONE NUMBER

SIGN HERE:

DA FORM 2028-2  
1 JUL 79

PREVIOUS EDITIONS ARE OBSOLETE.

P.S.—IF YOUR OUTFIT WANTS TO KNOW ABOUT YOUR RECOMMENDATION MAKE A CARBON COPY OF THIS AND GIVE IT TO YOUR HEADQUARTERS.

FILL IN YOUR  
UNIT'S ADDRESS

FOLD BACK

DEPARTMENT OF THE ARMY

\_\_\_\_\_  
\_\_\_\_\_

OFFICIAL BUSINESS  
PENALTY FOR PRIVATE USE \$300

POSTAGE AND FEES PAID  
DEPARTMENT OF THE ARMY  
DOD 314



TEAR ALONG PERFORATED LINE

Commander  
US Army Armament Materiel Readiness Command  
ATTN: DRSAR-MAS  
Rock Island, IL 61299



TM 9-4910-703-14&P ADAPTER SET, ENGINE MODEL 510-0 -- 1981